



Touch Think Intelligence Product Specification

Mainboard series

JWS3399-F

V1.4

www.touchthink.net

Shenzhen Touch Think Intelligence Co., Ltd.

CONTENTS

Chapter 1	
Introduction.....	- 3 -
1.1 Applicability.....	- 3 -
1.2 Functions.....	- 3 -
1.3 Features.....	- 3 -
Chapter 2 Basic Information.....	- 4 -
Chapter 3 PCB And Interface.....	- 5 -
3.1 PCB Drawing.....	- 6 -
3.2 Interface Parameter Definition.....	- 7 -
3.2.1 Power Input	- 8 -
3.2.2 RTC Battery	- 8 -
3.2.3 MIC	- 9 -
3.2.4 Indicator.....	- 9 -
3.2.5 Backlight Control	- 10 -
3.2.6 I/O Control.....	- 10 -
3.2.7 Dual LVDS Channel Interface.....	- 11 -
3.2.8 EDP Screen.....	- 13 -
3.2.9 Serial Interface*3.....	- 14 -
3.2.10 USB.....	- 14 -
3.2.11 Touch Screen(TP) Interface.....	- 15 -
3.2.12 MIPI LCD Interface.....	- 16 -
3.2.13 MIPI Camera	- 17 -
3.2.14 Headphone	- 19 -
3.2.15 Speaker	- 19 -
3.2.16 Ethernet.....	- 20 -
Chapter 4 Electrical Parameter.....	- 21 -
Chapter 5 Assembling Cautions.....	- 22 -

Chapter 1 Introduction

1.1 Applicability

JWS3399-F is a intelligent terminal motherboard can be applied in Advertising machine, digital signage, intelligent self-service terminal, intelligent vending machine, O2O smart equipment, industrial control computer, robot and other equipment.

1.2 Functions

JWS3399-F adopts RK3399 dual Cortex-A72 large core + quad Cortex-A53 small core 64-bit ultra-powerful CPU, main frequency 1.8GHz, Mali-T860 GPU, support 4K, H.265 hard decoding, Android 7.1 system. The board contains dual LVDS, eDP, HDMI display output interfaces, built-in universal backlight board interface, and screen voltage jumper, compatible with more kinds of displays, stronger performance, faster speed, and richer interfaces, it is your best choice for human-computer interaction, intelligent terminals, and industrial control projects.

1.3 Features

- Extremely compact, 121mm*81mm, suitable for small size smart display terminal equipment
- Support LVDS/MIPI/EDP three kinds of point screen interface, maximum support 4K 3840x2160 decoding and EDP 4K 3840x2160 point screen
- Rich expansion interfaces, 6 USB interfaces (5-way PH2.0 USB HOST (default three-way), 1-way USB OTG), 3-way TTL serial port, GPIO/ADC interface, can meet the requirements of the market for a variety of peripherals
- Integrated MIPI camera interface, supports up to 1300W HD MIPI camera
- Support Android system customization, provide system call interface API reference code, can provide face recognition API interface, perfect support for the customer's upper application APP development
- Perfectly support infrared, optical, capacitive, resistive, touch film and other mainstream touch screen, support the HID configuration of the driverless touch screen, no need for debugging

Chapter 2 Basic Informatio

Specifications	
CPU	JWS3399-F has the highest 64-bit high performance CPU, 1.8GHz 1. Dual Cortex-A72 Large-core + Quad Cortex-A53 Small-core 64-bit CPU 2. Built-in low-power MCU Cortex-M0
Memory	Standard 4G LPDDR4 +32G EMMC (8G/16G/64G optional)
ROM	2KB EEPROM (not included by default, optional sticker)
MIPI	MIPI*1, supports 1080P@60Hz
LVDS	LVDS*1, support single/dual channel 50/60Hz LCD
eDP	Maximum definition is 4K 3840*2160
Video Format	Support WMV, AVI, FLV, RM, RMVB, MPEG, TS, MP4 etc
Photograph Format	Support BMP, JPEG, PNG, GIF
AV Output	Support left and right channel output, built-in dual 4R/2.5W, 8Ω /1.5W amplifier
USB2.0	USB OTG*1, USB *3 (five interface optional)
Serial port	TTL*3
Ethernet	10M/100M adapt Ethernet
WIFI, BT	Built-in dual-frequency WIFI, BT4.0
Real Time Clock	Supported
Timing turn on/off	Supported
OS upgrade	Support upgrade through USB

Chapter 3 PCB And Interface

【Front】

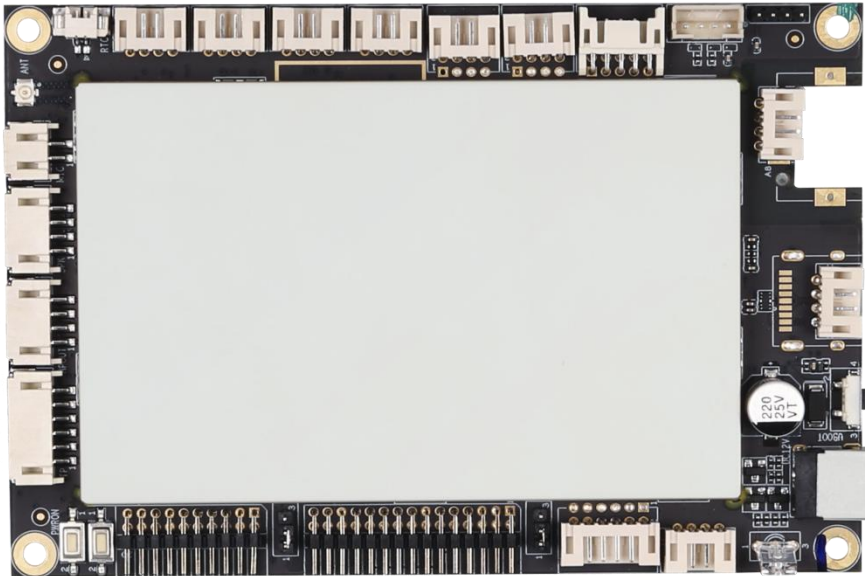

【Back】

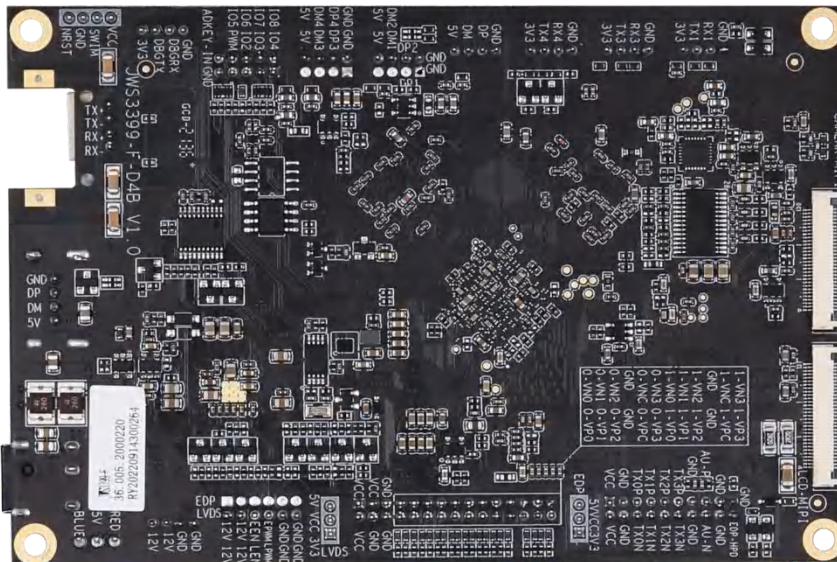

【Coastline interface】



3.1 PCB Drawing

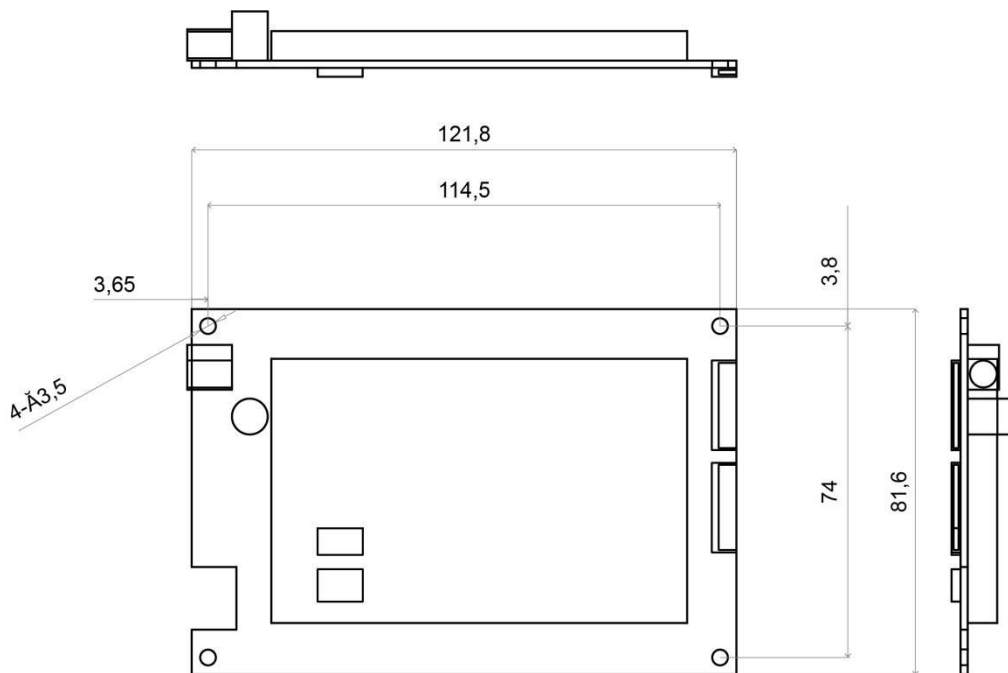

3.2 Interface Parameter Definition

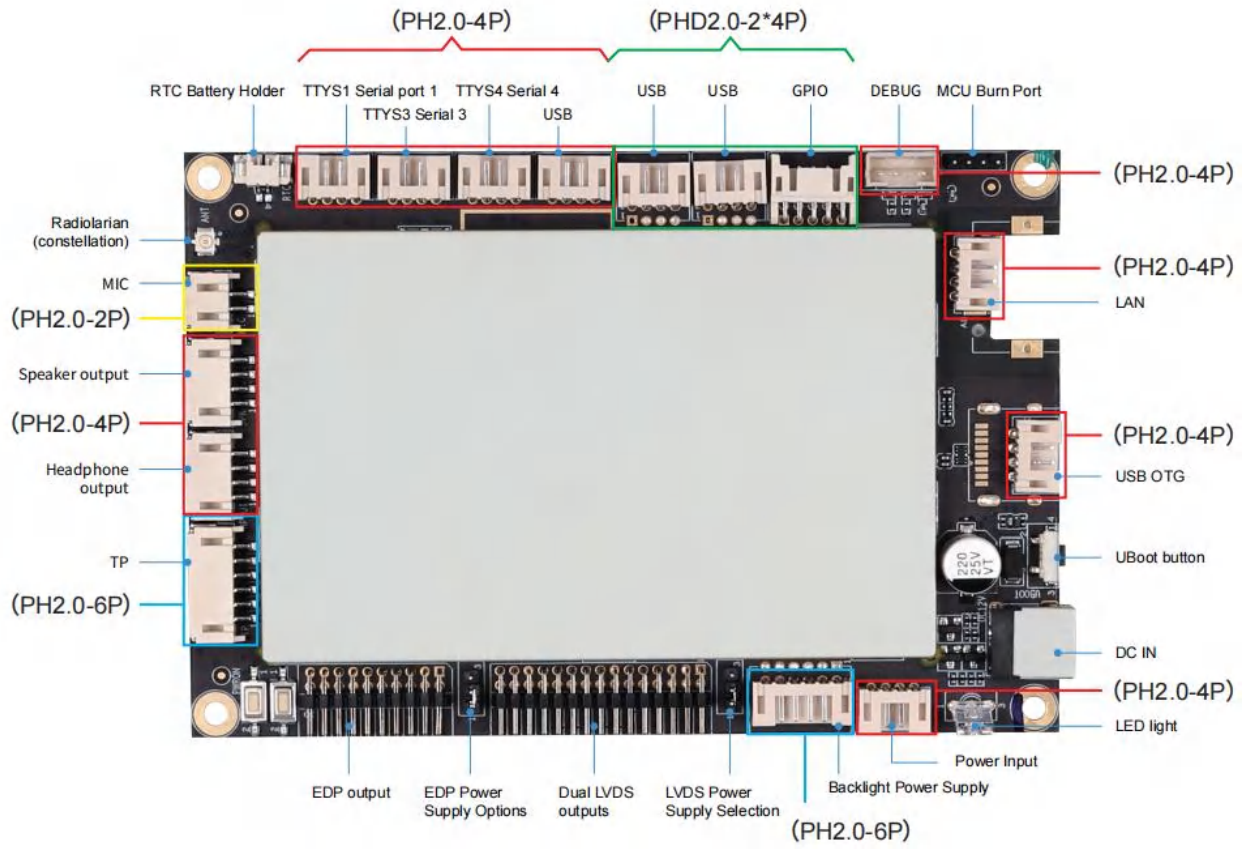

◆ 3.2.1 Power Input

Apply 12V DC power supply, motherboard can only uses power input from DC port or power input port, the adaptor DC input connector size is D5.5, d2.0.

When motherboard is under idling state, the minimum current 12V DC power supported is 600mA.

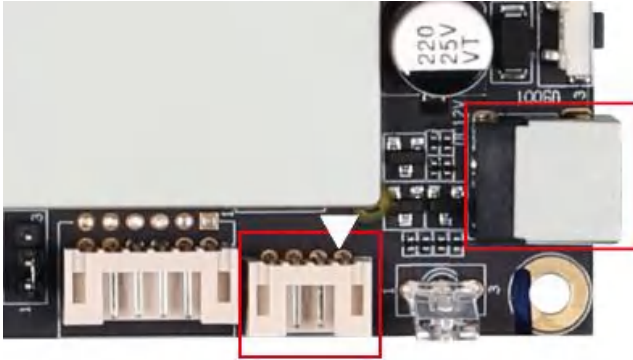

SN	DEFN	Property	Description
1	VCC	INPUT	12V Input
2	VCC	INPUT	12V Input
3	GND	GROUND	Ground
4	GND	GROUND	Ground

◆ 3.2.2 RTC Battery

This is a wafer 2pin port with 1.25mm pin pitch, it supply power to OS clock when peripheral power disconnect.



SN	DEEN	Property	Description
1	RTC	INPUT	3V Input
2	GND	GROUND	Ground

◆ 3.2.3 MIC

Please mind MIC P/N poles.

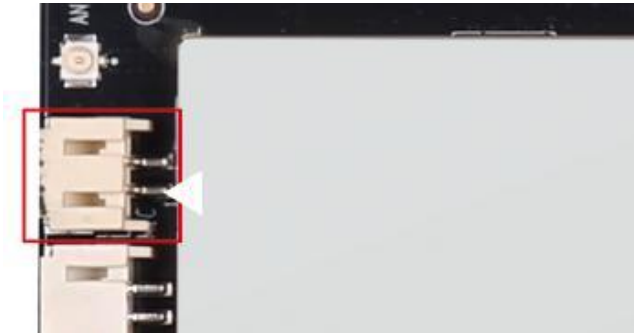

SN	DEEN	Property	Description
1	MIC1N	INPUT	MIC-
2	MIC1P	INPUT	MIC+

◆ 3.2.4 Indicator



SN	DEFN	Property	Description
1	LED_B	Blue	Work state indicator
2	VCC	Power	3.3V Output
3	LED_R	Red	Standby state indicator

◆ 3.2.5 Backlight Control

This port is designed for LVDS panel's backlight control function, the current of 12V power supply is 2A, if screen backlight power beyond 24W, in order to prevent system unstable, please connect backlight cable to another power panel. This interface can only be used to supply backlight power, never connect it to other device as power input.



SN	DEFN	Property	Description
1	GND	GROUND	Ground
2	GND	GROUND	Ground
3	BL_ADJ	OUTPUT	Backlight brightness control
4	BL_EN	OUTPUT	Backlight dis/enable control
5	VCC	Power	12V Output
6	VCC	Power	12V Output

◆ 3.2.6 I/O Control

This port provide I/O control signal for peripheral devices, level is 3.3V, ADC signal can be used as button control.

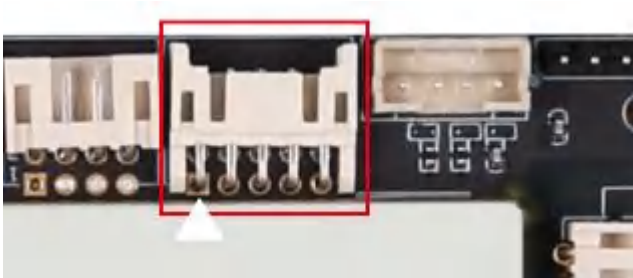

SN	DEFN	Property	Description
1	IO4	INPUT/OUT	GPIO Input/output
2	IO8	INPUT/OUT	GPIO Input/output
3	IO3	INPUT/OUT	GPIO Input/output
4	IO7	INPUT/OUT	GPIO Input/output
5	IO2	INPUT/OUT	GPIO Input/output
6	IO6	INPUT/OUT	GPIO Input/output
7	PWM	OUTPUT	PWM Output
8	IO5	INPUT/OUT	GPIO Input/output
9	GND	GROUND	Ground
10	ADC	INPUT	ADC Signal

◆ 3.2.7 Dual LVDS Channel Port

Common LVDS pin definition, support single/dual, 6/8bit LVDS panel, user can change port voltage level by move jumper cap position, 3.3V/5V/12V optional.

To prevent board and screen panel burning-out, please notice below:

1. Confirm LVDS screen panel's voltage in SPEC is correct and it's correspond to motherboard power supply, please also confirm that motherboard can provide maximum current which LVDS screen panel required.
2. Please use multimeter to test motherboard output voltage, make sure jumper cap mounted on the right position.



SN	DEFN	Property	Description
1	VCC	Power OUTPUT	LCD power Output, +3.3v/+5V(Optional)
2			
3			
4	GND	GROUND	Ground
5			
6			
7	0-VN0	OUTPUT	Pixel0 Negative Data(Odd)
8	0-VN0	OUTPUT	Pixel0 Positive Data(Odd)
9	0-VN1	OUTPUT	Pixel1 Negative Data(Odd)
10	0-VP1	OUTPUT	Pixel1 Positive Data(Odd)
11	0-VN2	OUTPUT	Pixel2 Negative Data(Odd)
12	0-VP2	OUTPUT	Pixel2 Positive Data(Odd)
13	GND	GROUND	Ground
14	GND	GROUND	Ground
15	0-VNC	OUTPUT	Negative sampling clock(Odd)
16	0-VPC	OUTPUT	Positive sampling clock(Odd)
17	0-VN3	OUTPUT	Pixel3 Negative Data(Odd)
18	0-VP3	OUTPUT	Pixel3 Positive Data(Odd)
19	1-VN0	OUTPUT	Pixel0 Negative Data(Even)
20	1-VP0	OUTPUT	Pixel0 Positive Data(Even)
21	1-VN1	OUTPUT	Pixel1 Negative Data(Even)
22	1-VP1	OUTPUT	Pixel1 Positive Data(Even)
23	1-VN2	OUTPUT	Pixel2 Negative Data(Even)
24	1-VP2	OUTPUT	Pixel2 Positive Data(Even)
25	GND	GROUND	Ground
26	GND	GROUND	Ground
27	1-VNC	OUTPUT	Negative sampling clock(Even)
28	1-VPC	OUTPUT	Positive sampling clock(Even)
29	1-VN3	OUTPUT	Pixel3 Negative Data(Even)
30	1-VP3	OUTPUT	Pixel3 Positive Data(Even)

◆ 3.2.8 EDP Screen

In the above picture, the jumper cap is used to select the screen power supply, you can choose: 12V/5V/3.3V, please refer to the silkscreen on the back of the PCB carefully.

The electrical definition of the output interface, pay attention to the first pin of the 20PIN plug-in position, if inserted in reverse, it is easy to burn the EDP screen.

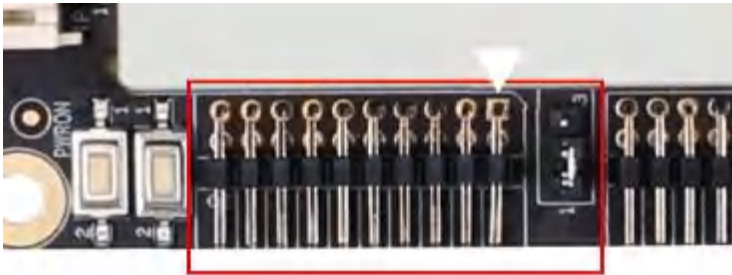

SN	DEFN	Property	Description
1	VCC	Power	LCD Power Output, +3.3V/+5V
2	VCC	Power	LCD Power Output, +3.3V/+5V
3	GND	GROUND	Ground
4	GND	GROUND	Ground
5	TX0N	OUTPUT	EDP Pixel0 Negative Data (Odd)
6	TX0P	OUTPUT	EDP Pixel0 Positive Data (Odd)
7	TX1N	OUTPUT	EDP Pixel1 Negative Data (Odd)
8	TX1P	OUTPUT	EDP Pixel1 Positive Data (Odd)
9	TX2N	OUTPUT	EDP Pixel2 Negative Data (Odd)
10	TX2P	OUTPUT	EDP Pixel2 Positive Data (Odd)
11	TX3P	OUTPUT	EDP Pixel3 Negative Data (Odd)
12	TX3P	OUTPUT	EDP Pixel3 Positive Data (Odd)
13	GND	GROUND	Ground
14	GND	GROUND	Ground
15	AU-N	OUTPUT	EDP AUX Negative Data (Odd)
16	AU-P	OUTPUT	EDP AUX Positive Data (Odd)
17	GND	GROUND	Ground
18	GND	GROUND	Ground
19	GND	GROUND	Ground
20	HPD	GROUND	EDP DETECT

◆ 3.2.9 Serial Interface*3



SN	DEFN	Property	Description
1	GND	GROUND	Ground
2	RX	INPUT	TTL-RX
3	TX	OUTPUT	TTL-TX
4	3V3	Power	3.3V Output

◆ 3.2.10 USB

Motherboard provides a USB standard port and three internal USB ports(user can change two switchable interface to USB, therefor board can provide 5 USB ports in total). all those ports' USB mode is HOST and the current is less than 1A. the USB standard(on facial recognition terminal it will be changed to PH2.0 socket)interface can be switched to OTG mode through OS settings.

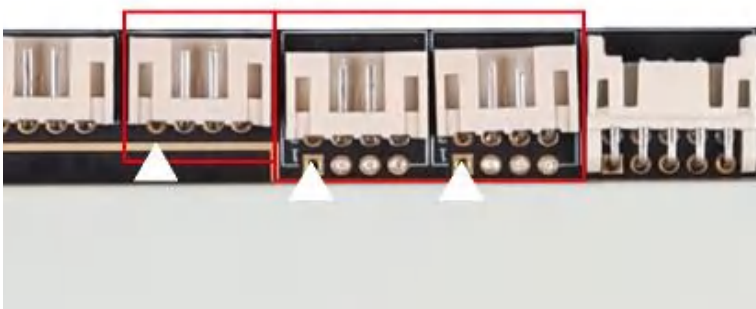

OTG:

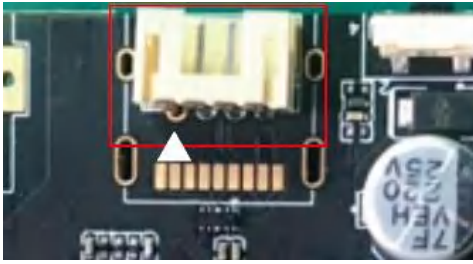

OR

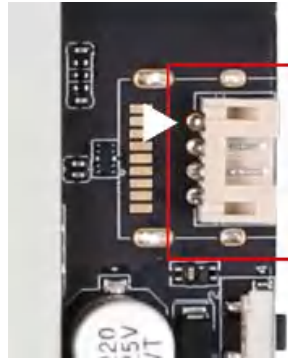

SN	DEFN	Property	Description
1	VCC	Power	5V Output
2	DM	INPUT/OUTPUT	DM
3	DP	INPUT/OUTPUT	DP
4	GND	GROUND	Ground

◆ 3.2.11 Touch Screen(TP)

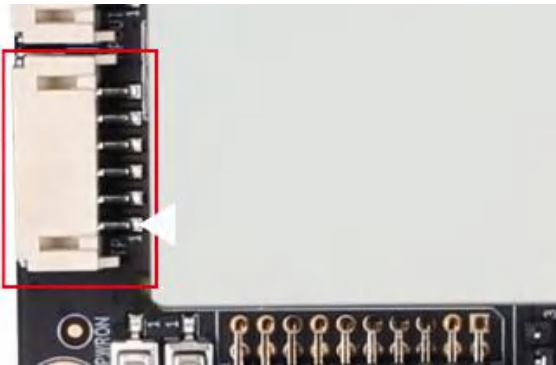

SN	DEFN	Property	Description
1	VCC	Power	3.3V Output
2	SCK	INPUT/OUTP	I2C Clock
3	SDA	INPUT/OUTP	I2C Data
4	INT	INPUT/OUTP	Interrupt
5	RST	INPUT/OUTP	Reset
6	GND	GROUND	Ground

◆ 3.2.12 MIPI LCD

To prevent motherboard and screen panel burning-out, please notice below:

1. Confirm MIPI LCD electrical parameter in SPEC is correct and its request is in consonance with board power supply.
2. Please confirm pin definition on board and screen interface is the same, make sure FPC cable is correct.

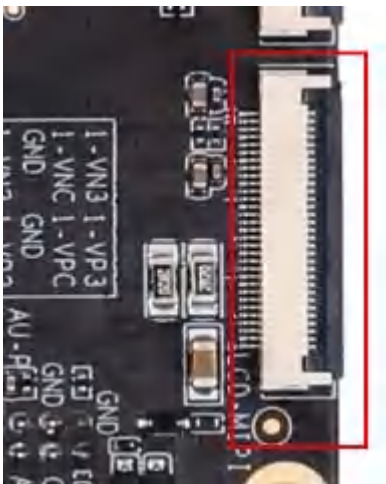

SN	DEFN	Property	Description
1	LED+	Power	Backlight power input positive
2	LED+	Power	Backlight power input positive
3	LED+	Power	Backlight power input positive
4	NC	NC	NC
5	LED-	Power	Backlight power input negative
6	LED-	Power	Backlight power input negative
7	LED-	Power	Backlight power input negative
8	LED-	Power	Backlight power input negative
9	GND	GROUND	Ground
10	GND	GROUND	Ground
11	MIPI_D	OUTPUT	MIPI Port Lane 2 positive output
12	MIPI_D	OUTPUT	MIPI Port Lane 2 negative output
13	GND	GROUND	Ground
14	MIPI_D	OUTPUT	MIPI Port Lane 1 positive output
15	MIPI_D	OUTPUT	MIPI Port Lane 1 negative output

16	GND	GROUND	Ground
17	MIPI_C	OUTPUT	MIPI Port clock positive output
18	MIPI_C	OUTPUT	MIPI Port clock negative output
19	GND	GROUND	Ground
20	MIPI_D	OUTPUT	MIPI Port Lane 0 positive output
21	MIPI_D	OUTPUT	MIPI Port Lane 0 negative output
22	GND	GROUND	Ground
23	MIPI_D	OUTPUT	MIPI Port Lane 3 positive output
24	MIPI_D	OUTPUT	MIPI Port Lane 3 negative output
25	GND	GROUND	Ground
26	VCC1V	Power	1V8 power supply
27	REST	GROUND	Reset signal
28	GND	GROUND	Ground
29	VCC1V	Power	1V8 power supply
30	VCCIO	Power	IO power supply
31	VCCIO	Power	IO power supply

◆ 3.2.13 MIPI Camera

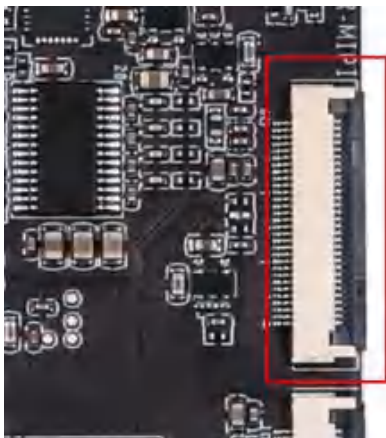

SN	DEFN	Property	Description
1	NC	/	/
2	VDD	Power	2.8V Output
3	DVDD	Power	1.2V Output
4	DOVDD	Power	1.8V Output
5	NC	/	/
6	GND	GROUND	Ground
7	VDD	Power	2.8V Output
8	GND	GROUND	Ground
9	I2C3_SDA	INPUT/OUT	SDA Signal
10	I2C3_SCL	OUTPUT	SCL Signal
11	RST	OUTPUT	Reset Signal
12	PWDN	OUTPUT	Power Down
13	GND	GROUND	Ground
14	MCLK	OUTPUT	Main Clock
15	GND	GROUND	Ground
16	D3P	INPUT/OUT	MIPI Data Channel 3 Positive
17	D3N	INPUT/OUT	MIPI Data Channel 3 Negative
18	GND	GROUND	Ground
19	D2P	INPUT/OUT	MIPI Data Channel 2 Positive
20	D2N	INPUT/OUT	MIPI Data Channel 2 Negative
21	GND	GROUND	Ground
22	D1P	INPUT/OUT	MIPI Data Channel 1 Positive
23	D1N	INPUT/OUT	MIPI Data Channel 1 Negative
24	GND	GROUND	Ground
25	CLKP	INPUT/OUT	MIPI Clock Channel Positive
26	CLKN	INPUT/OUT	MIPI Clock Channel Negative
27	GND	GROUND	Ground
28	D0P	INPUT/OUT	MIPI Data Channel 0 Positive
29	D0N	INPUT/OUT	MIPI Data Channel 0 Negative
30	GND	GROUND	Ground

◆ 3.2.14 Headphone

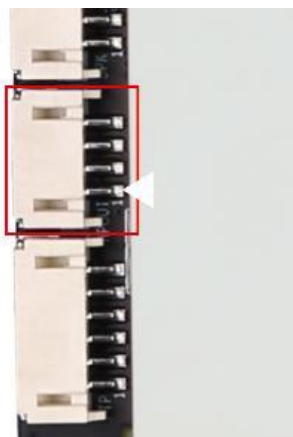

SN	DEFN	Property	Description
1	HPR	INPUT	Audio output right
2	GND	GROUND	Ground
3	HPL	INPUT	Audio output left
4	HP_DET	OUTPUT	Headphone detect

◆ 3.2.15 Speaker



SN	DEFN	Property	Description
1	OUTP-L	OUTPUT	Audio output left positive
2	OUTN-L	OUTPUT	Audio output left negative
3	OUTN-R	OUTPUT	Audio output right negative
4	OUTP-R	OUTPUT	Audio output right positive

◆ 3.2.16 Ethernet

Motherboard support 100M Ethernet, this port is optional(RJ45 or 4Pin PH2.0).

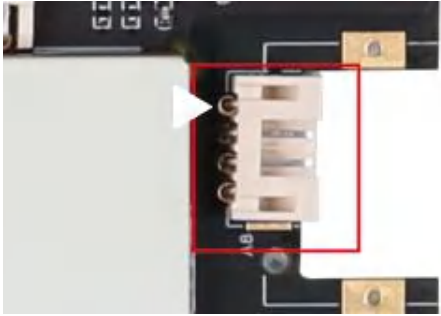

OR

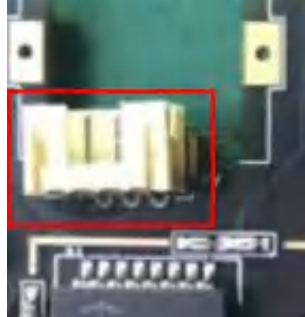

Chapter 4 Electrical Parameter

ITEM		MIN	NORMAL	MAX
Power	Voltage	--	12V	--
	Ripple	--	--	50mV
	Current	3A		
Working parameter	Work	--	200mA	350mA
	Standby	--	17mA	20mA
	USB Supply	--	--	500mA
LVDS	3.3V 流		400 mA	1A
	5V		550 mA	2A
	USB power supply	--	--	1A
EDP	3.3V		400 mA	500 mA
	5V	--	--	--
	USB power supply	--	--	1A
Total output	Current	3.3V		600mA
Environment	Relative humidity	--	--	80%
	Operating temperature	0°C	--	60°C
	Storage temperature	-20°C		70°C

Remark 1:

Please chose the right backlight working voltage(3.3V,5V) for LVDS screen. To prevent device burnout, please confirm LVDS screen' s maximum working current before connect it to our motherboard.

Remark 2:

When connect motherboard to EDP/LVDS screen, motherboard' s working voltage and current is depend on EDP/LVDS screen, therefore we didn' t list those parameter on above list.

Chapter 5 Assembling Cautions

During assembling, please pay attention to notes below.

1. No short circuit between board and device;
2. Avoid motherboard bend or twist when mounted on user's device frame;
3. Confirm LVDS/EDP screen's requested voltage and current is correspond to motherboard output, mind the connector's pin definition and connect the pin correctly;
4. If backlight power requested is beyond 20W, please connect backlight to another power board;
5. When user mounting peripheral device(USB,IO etc), please mind the IO level and current output ;
6. When mounting serial port,pleas mind whether 232/485 device is connected and TX/RX pin connected correctly;
7. Check whether power input connected to input interface, make sure total input voltage and total input current suit user's request, please don't use backlight interface to supply power to other device.